

## IGBT Modules

VCES

IC

Applications

Features

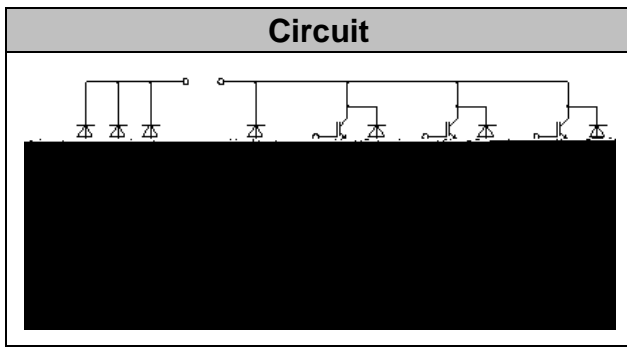

### IGBT- inverter

#### Absolute Maximum Ratings

Parameter	Symbol	Conditions	Value	Unit

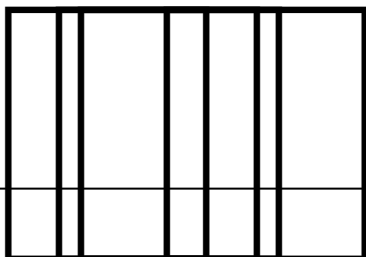





O I 37R34R4

RoHS  
COMPLIANT

### Diode-inverter Absolute Maximum Ratings

Parameter	Symbol	Conditions	Value			Unit
			Min.	Typ.	Max.	

### Characteristic values

Parameter	Symbol	Conditions	Value			Unit
			Min.	Typ.	Max.	

--	--	--	--	--	--



## IGBT-brake-chopper Absolute Maximum Ratings

Parameter	Symbol	Conditions	Value	Unit

## Characteristic values

Parameter	Symbol	Condition	Value		Unit
			Min.	Typ.	

--	--	--	--	--



O I 37R34R4

RoHS  
COMPLIANT

**Diode-Brake-Chopper  
Absolute Maximum Ratings**

Reference

Symbol

Conditions

Value

Unit

$R_{I \leq p} \leq 100\% \text{ TC } @ T_{E} = 9$

--	--	--	--	--





O I 37R34R4

RoHS  
COMPLIANT

Module Characteristics

Parameter	Symbol	Conditions	Value			Unit
			Min.	Typ.	Max.	

--	--	--	--	--	--





--	--	--	--	--	--

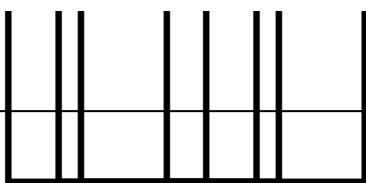
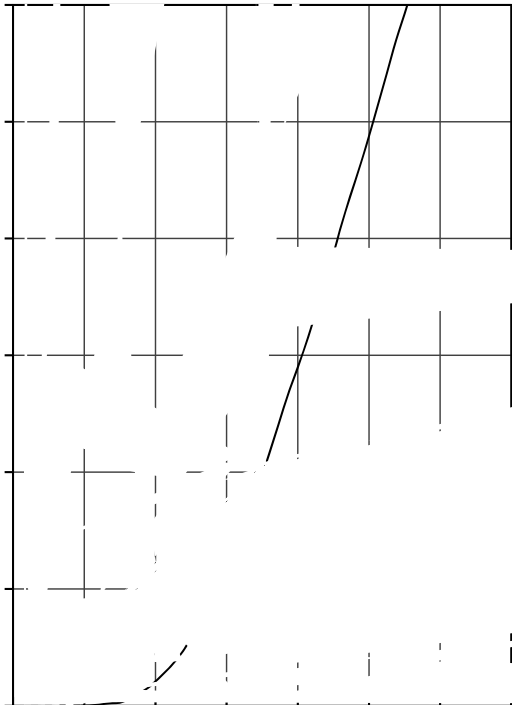
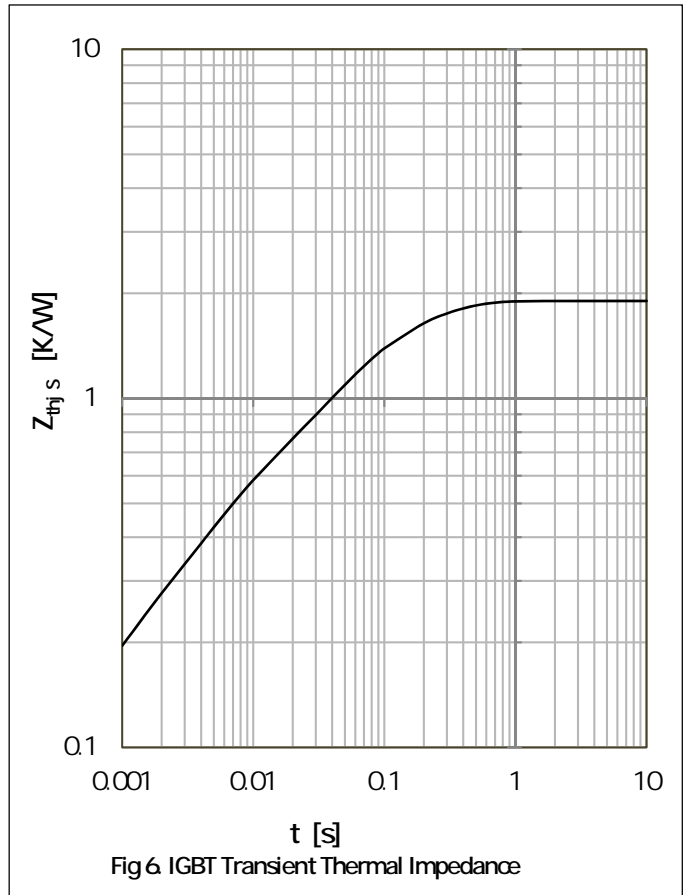
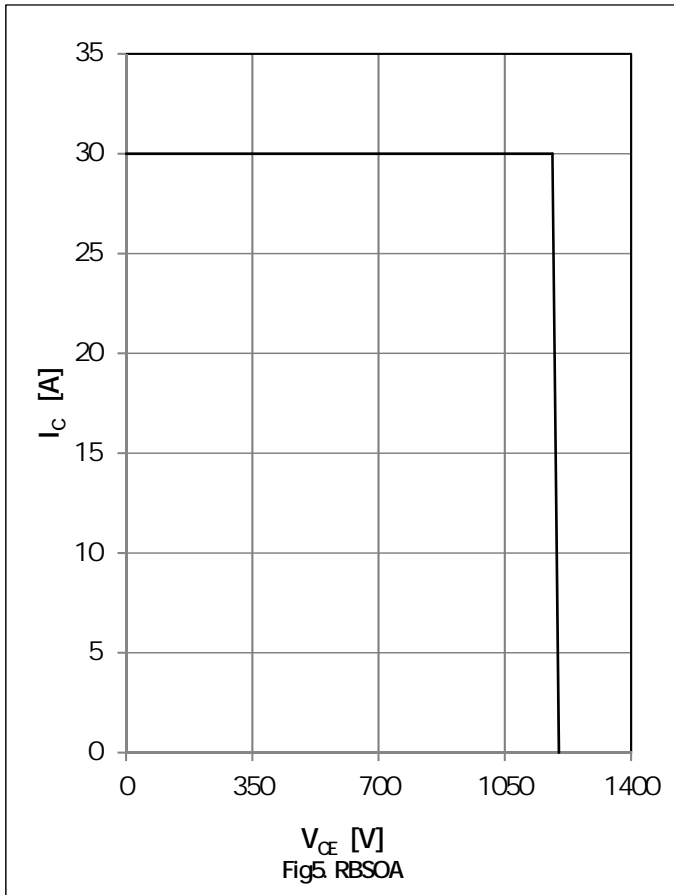



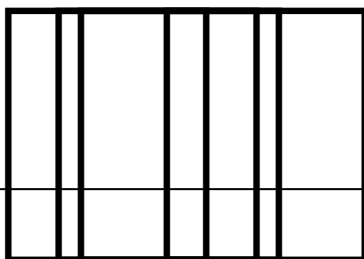
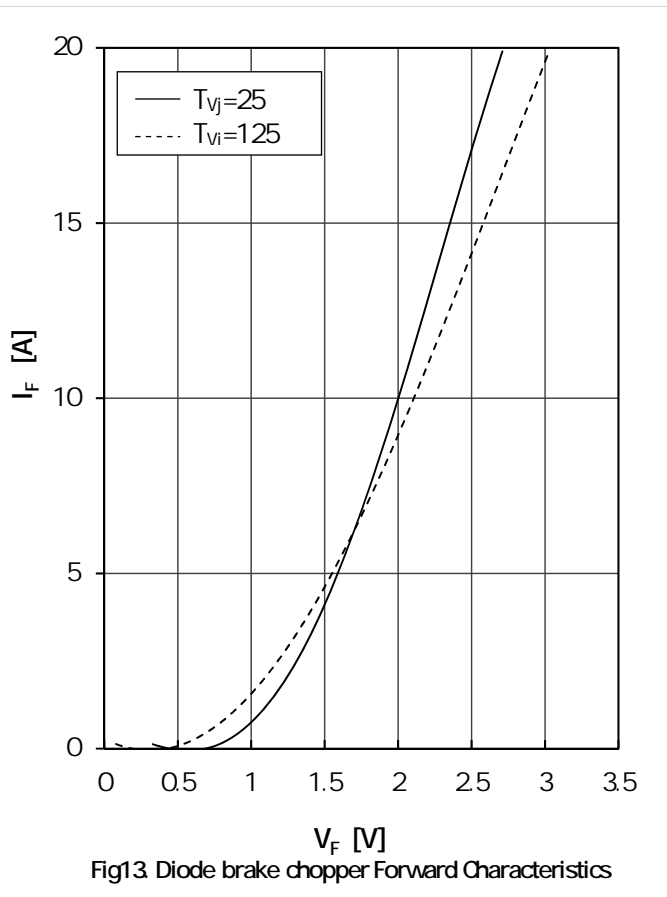

**O I 37R34R4**





# O I 37R34R4

RoHS  
COMPLIANT

## Circuit Diagram

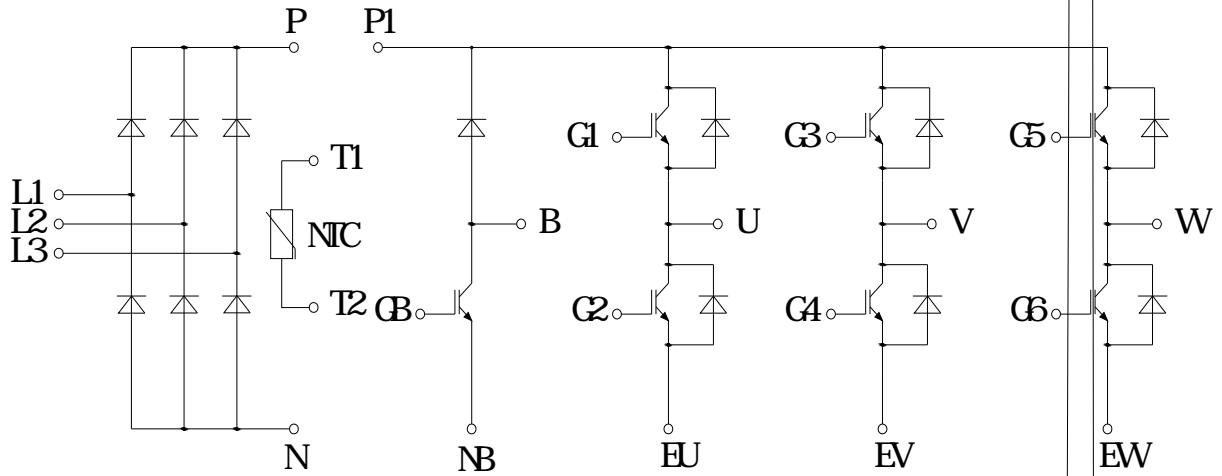

## Package Dimensions

