

1. (CTR: .50% $I_F=5mA$, $V_{CE}=5V$)
 2. ($V_{ISO}=5,000V_{rms}$)
 3. (tr: TYP. 4 μs $V_{CE}=2V$, $I_C=2mA$, $R_L=100\Omega$)
 4. UL (.E236324)
 5. CSA (.218896)
 6. VDE (.40007240)
 7. TUV (.R50029014)

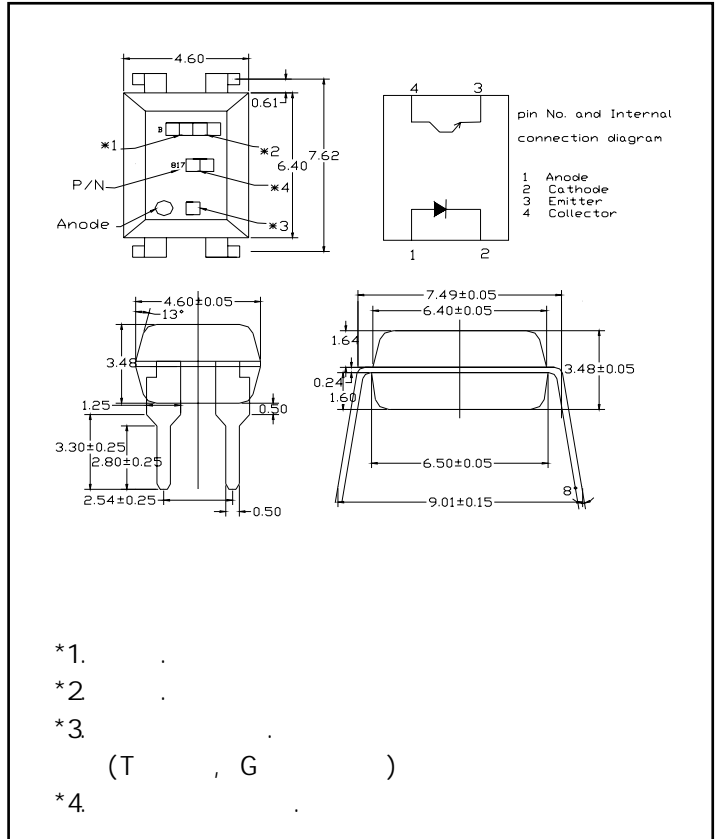

GaAs

1. BPC-817 NPN
 2. BPC-817 BIN 2.54mm

1.
2.
3.
4.
5.

(=25)

		I_F	50	mA
		V_R	6	V
		P	70	mW
		V_{CEO}	35	V
		V_{ECO}	6	
		I_C	50	mA
		P_C	150	mW
		P_{tot}	200	mW
	*1	V_{iso}	5,000	Vrms
		V_{IOTM}	6,000	V
		V_{IORM}	630	V
		T_{opr}	-30 to + 100	
		T_{stg}	-55 to + 125	
	*2	T_{sol}	260	

*1. =40~60%

- (1)
(2)
(3)

*2. 10

($T_a=25$)

		V_F	$I_F=20\text{mA}$	---	1.2	1.4	V
		I_R	$V_R=4\text{V}$	---	---	10	μA
		C_t	$V=0, f=1\text{KHz}$	---	30	250	pF
		I_{CEO}	$V_{CE}=20\text{V}, I_F=0$	---	---	100	nA
		BV_{CEO}	$I_C=0.1\text{mA}$ $I_F=0$	35	---	---	V
		BV_{ECO}	$I_E=10\mu\text{A}$ $I_F=0$	6	---	---	V
		I_c	$I_F=5\text{mA}$	2.5	---	30	mA
	*1	CTR	$V_{CE}=5\text{V}$	50	---	600	%
		$V_{CE(sat)}$	$I_F=20\text{mA}$ $I_C=1\text{mA}$	---	0.1	0.2	V
		R_{iso}	DC500V 40~60%R.H.	5×10^{10}	1×10^{11}	---	Ω
		C_f	$V=0, f=1\text{MHz}$	---	0.6	1	pF
		f_c	$V_{CE}=5\text{V},$ $I_C=2\text{mA}$ $R_L=100\Omega,$ -3dB	---	80	---	kHz
		t_r	$V_{CE}=2\text{V},$ $I_C=2\text{mA}$	---	4	18	μs
		t_f	$R_L=100\Omega$	---	3	18	μs

*1 $\text{CTR} = I_c / I_F \times 100\%$

	. (%)	. (%)
L	50	100
A	80	160
B	130	260
C	200	400
D	300	600
L or A or B or C or D	50	600

:

1. : $I_F=5\text{mA}, V_{CE}=5\text{V}, T_a=25$.

Fig.1 Forward Current vs. Ambient Temperature

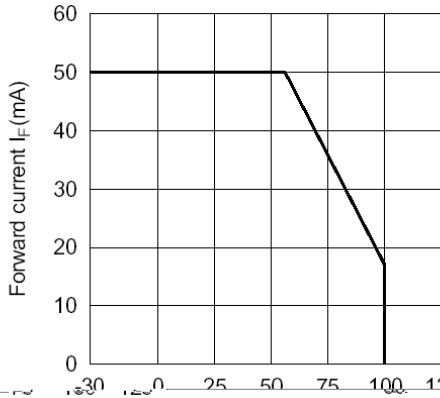
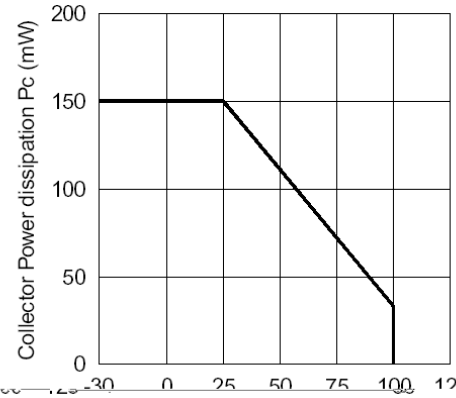

Fig.2 Collector Power Dissipation vs. Ambient Temperature



Forward Current vs. Forward Voltage

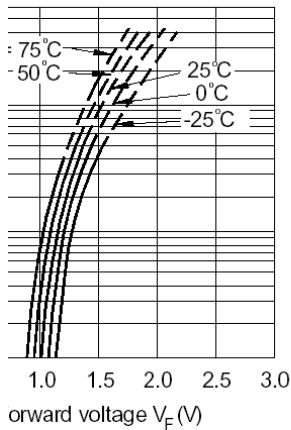

Fig.3 Collector-emitter Saturation Voltage vs. Forward Current

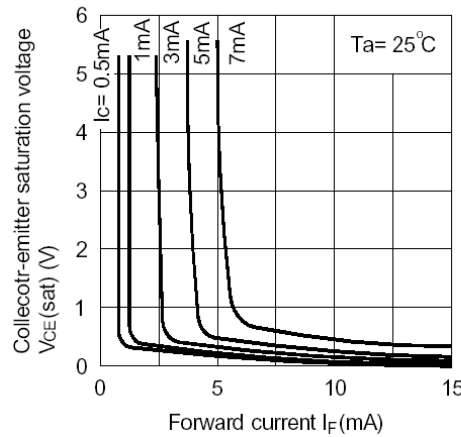
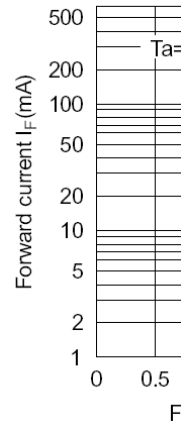

Fig.4 Forward Current vs. Forward Voltage



Forward Current vs. Collector-emitter Voltage

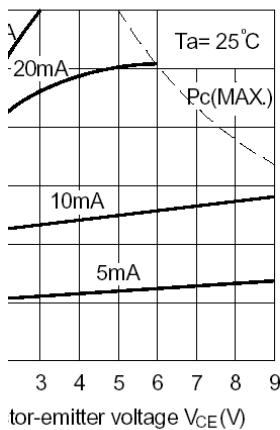

Fig.5 Current Transfer Ratio vs. Forward Current

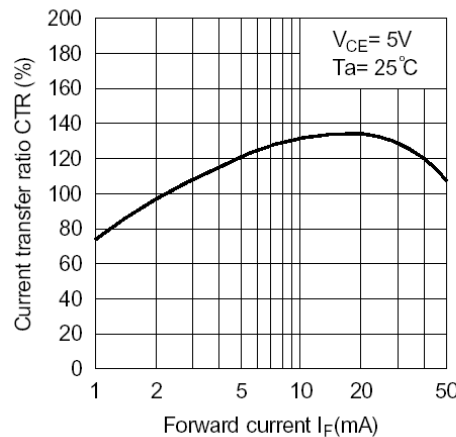

Fig.6 Collector Current vs. Collector-emitter Voltage

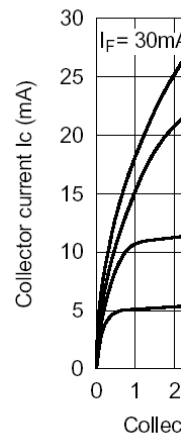

Fig.7 Relative Current Transfer Ratio vs. Ambient Temperature

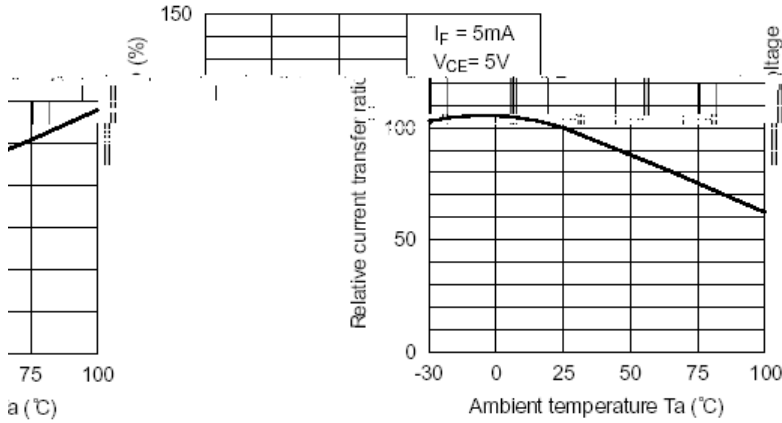

Fig.8 Collector-emitter Saturation Voltage vs. Ambient Temperature

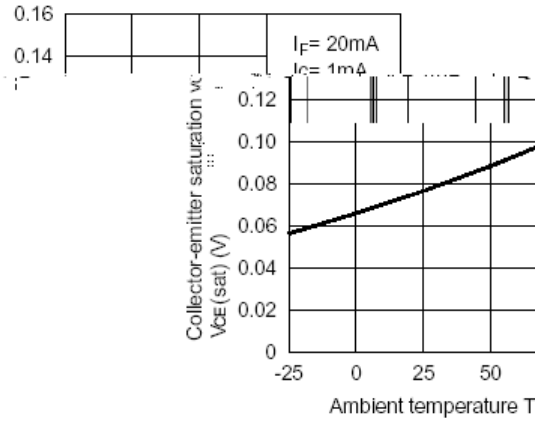

Fig.9 Collector Dark Current vs. Ambient Temperature

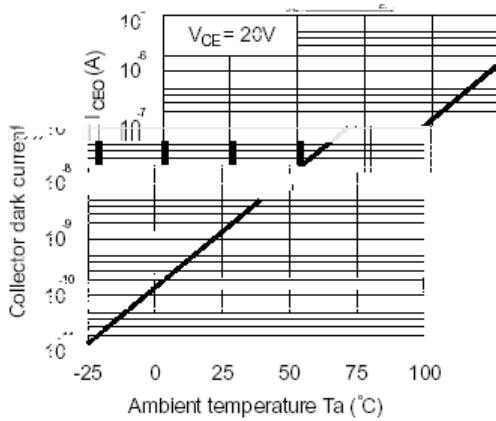

Fig.10 Response Time vs. Load Resistance

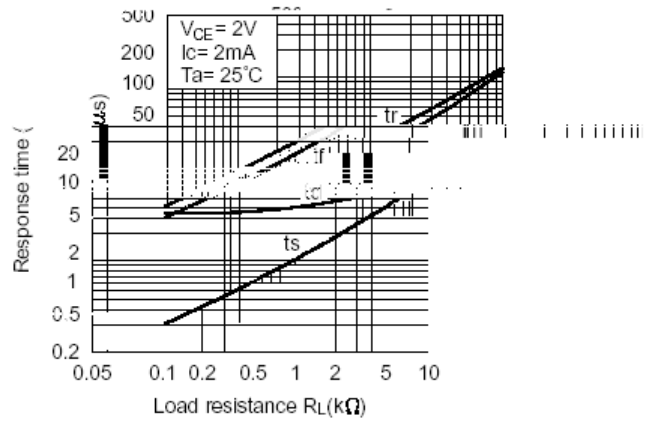
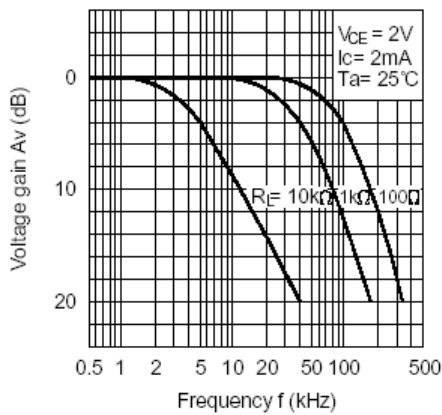
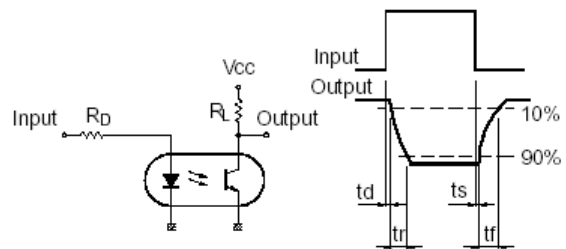

Fig.11 Frequency Response



Test Circuit for Response Time



Test Circuit for Frequency Response

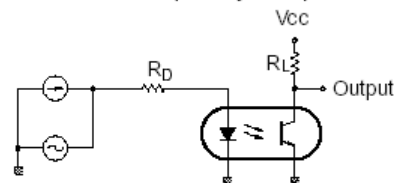

		MIL-STD-750: 1026 MIL-STD-883: 1005 JIS C 7021 : B-1	$I_f = 50mA$ 1000	0/20 JU	Ja
--	--	--	----------------------	------------	----

é

~ y

C 7021 : B-1